

Valve Standard

Conforms to AWWA C515 / BS5163
Fusion bonded coating comply with AWWA C550

Sizes

2", 2.5", 3", 4", 5", 6", 8", 10", 12"

Working pressure

300PSI

Connection Ends

AWWA C 606

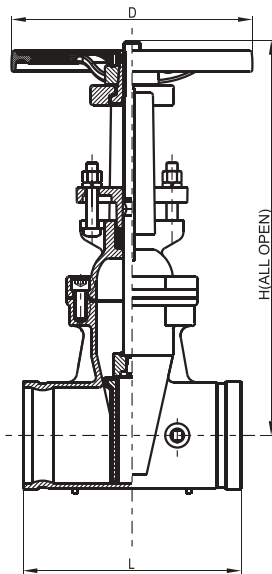

Materials List

Part Name	Material	Specification
Body	Ductile Iron	A536 65-45-12
Wedge	Ductile Iron EPDM Coated	
Wedge Nut	Stainless Steel	AISI304
Stem	Stainless Steel	AISI 304/420
Bonnet	Ductile Iron	A536 65-45-12
Gasket	EPDM	Commercial
Packing	Graphite	Non-asbestos
Stem Nut	Bronze	ASTM B62
Handwheel	Ductile Iron	A536 65-45-12

Dimensions (mm/inch)

SIZE	mm	50	65	80	100	125	150	200	250	300
	inch	2	2 1/2	3	4	5	6	8	10	12
L	mm	178.0	191.0	203.0	229.0	254.0	267.0	292.0	330.0	356.0
	inch	7.00	7.50	8.00	9.00	10.00	10.50	11.50	13.00	14.00
H	mm	411	411	462	514	629	709	922	1116	1300
	inch	16.18	16.18	18.19	20.24	24.76	27.91	36.30	43.94	51.18
D	mm	183	183	253	253	306	306	355	445	445
	inch	7.20	7.20	9.96	9.96	12.05	12.05	13.98	17.52	17.52

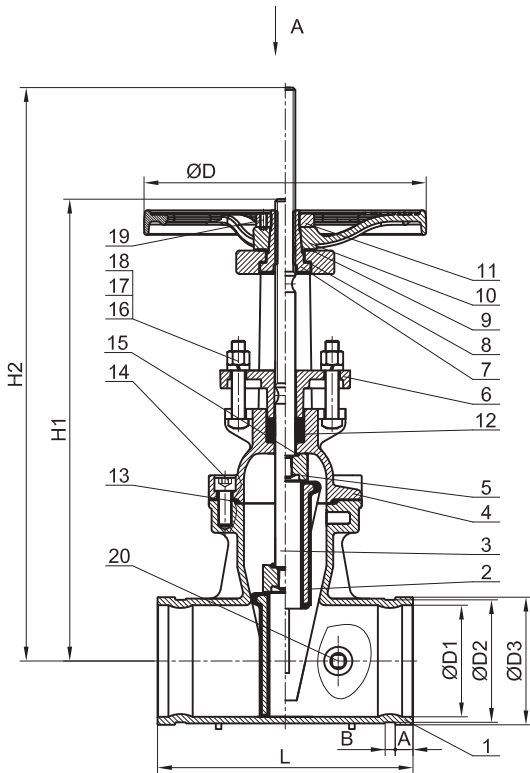

SIZE	DN50	DN65	DN80	DN100	DN125	DN150	DN200	DN250	DN300
L	178	191	203	229	254	273	292	330	356
H1	337	337	376	414	497	561	714	856	993
H2	411	411	462	514	629	709	922	1116	1300
ΦD	183	183	253	253	306	306	355	445	445
A	15.9	15.9	15.9	15.9	15.9	15.9	19	19	19
B	8	8	8	9.5	9.5	9.5	11	12.7	12.7
ØD1	50	65	80	100	125	150	200	250	300
ØD2	57	68.9	84.7	109.8	136.8	163.7	214.1	268	317.9
ØD3	60.3	73	88.9	114.3	141.3	168.3	219.1	273	323.9
Open the number of turns	13	17	16	20	25	30	34	42	50

A DIRECTION VIEW

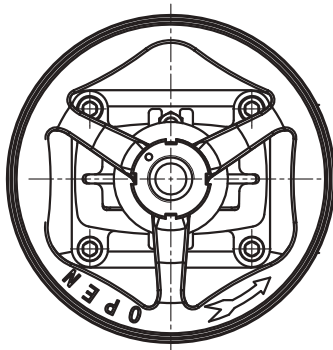

Item	Name	Material
20	PLUG	ASTM SS304
19	HEX CYLINDER HEAD SET SCREWS	ASTM SS304
18	SPRING WASHER	ASTM SS304
17	SQ BOLT	ASTM SS304
16	NUT	ASTM SS304
15	O-RING	EPDM
14	HEX.SOCKET CAP SCREW	8.8 RATING
13	GASKET	EPDM
12	PACKING	PTFE
11	HANDWHEEL NUT	CARBON STEEL GALVANZATION
10	HANDWHEEL	ASTM A536 65-45-12
9	HANDWHEEL WASHER	ASTM B16
8	STEM NUT WASHER	ASTM B16
7	STEM NUT	ASTM B62
6	GLAND	ASTM A536 65-45-12
5	DISC NUT	ASTM A351 CF8
4	BONNET	ASTM A536 65-45-12
3	STEM	AISI SS304
2	WEDGE	ASTM A536 65-45-12+EPDM
1	BODY	ASTM A536 65-45-12

Pressure - Temperature Chart

